

CONSTRUCTION NOTES:

1. PULL BOX NUMBER 1 (TYPE "B") SHALL CONTAIN CABLES FOR PEDESTRIAN DETECTION.
2. ALL SEPERATELY GROUNDED ELEMENTS AT AN INTERSECTION SHALL BE BONDED TOGETHER TO FORM AN INTERSECTION GROUNDING NETWORK.
3. GROUND WIRE SHALL BE #6 STRANDED.
4. ALL CONDUIT TERMINATIONS SHALL HAVE BELL ENDS.

## TYPICAL PEDESTRIAN PUSH BUTTON POLE DETAIL

NOT TO SCALE

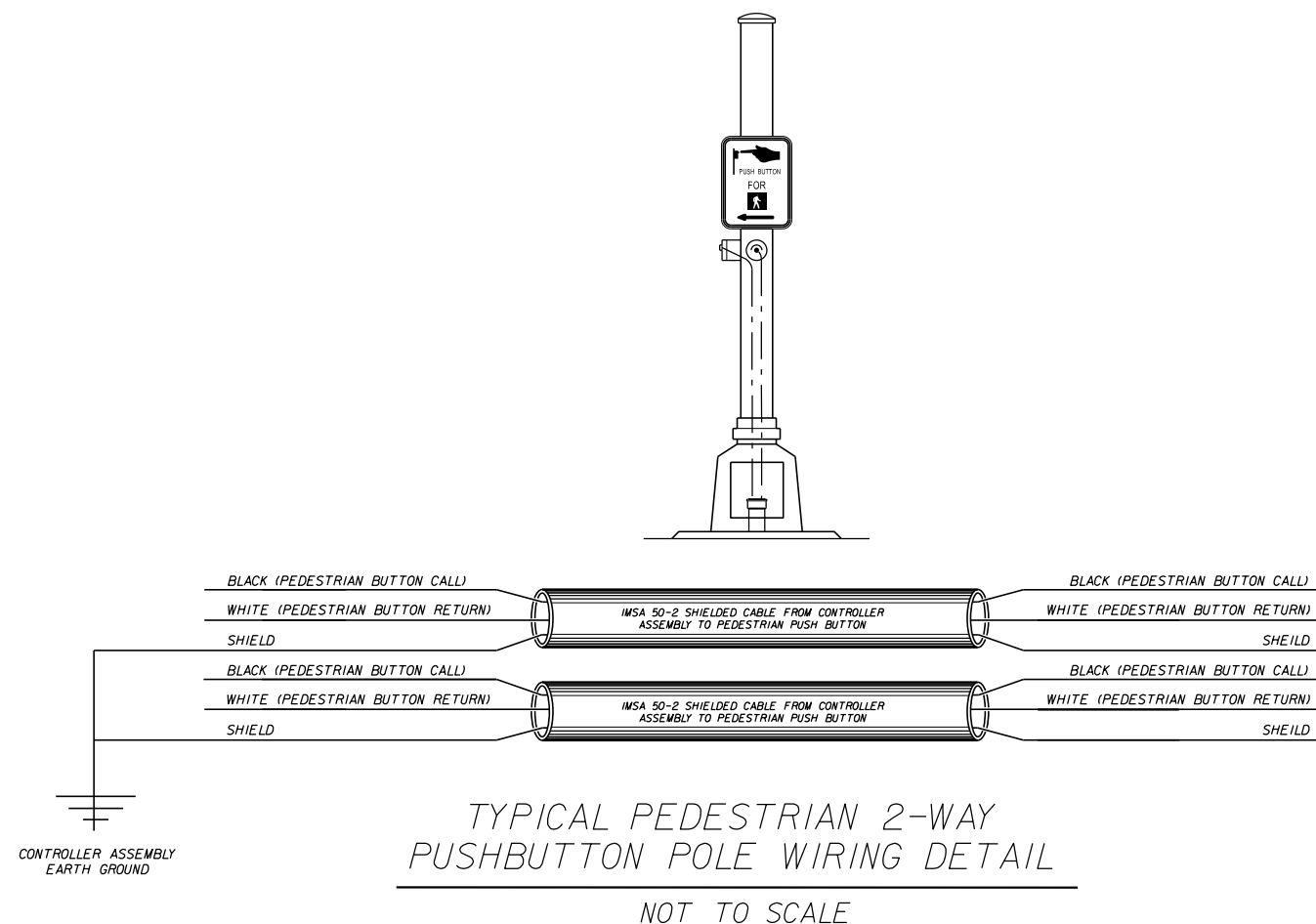
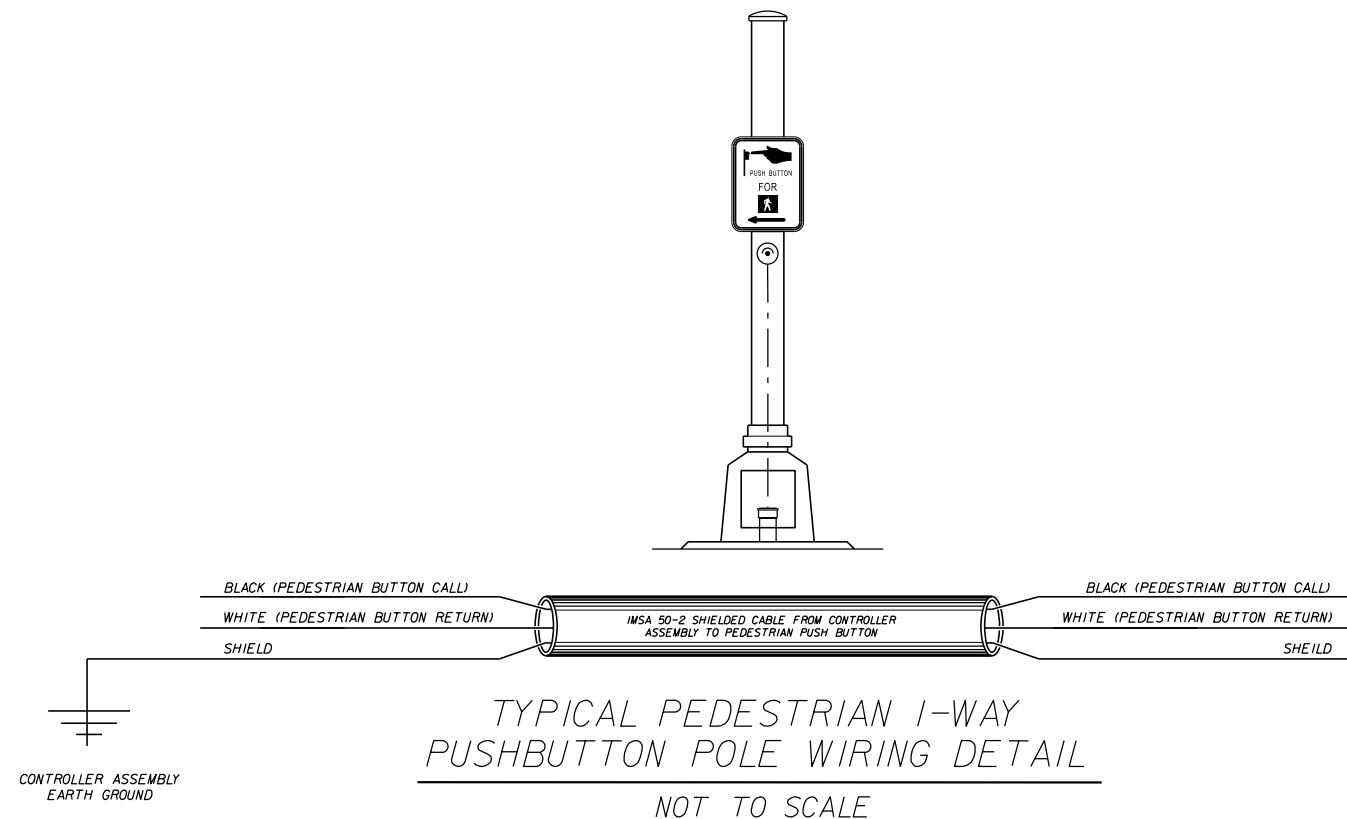

REVISIONS					
DATE	BY	DESCRIPTION	DATE	BY	DESCRIPTION



Collier County Traffic Operations  
2885 South Horseshoe Drive  
Naples, Florida 34104  
Phone: (239) 252-8260  
Fax: (239) 252-5868

COLLIER COUNTY  
GROWTH MANAGEMENT DIVISION

PEDESTAL MOUNTED PEDESTRIAN  
PUSH BUTTON DETAILS

SHEET NO.  
TSP-21